



IC18A

BENCH TOP ICE CUBE MACHINE AND DISPENSER

Brema's IC range offers self-contained ice machines for bench top, under bench or free-standing installation. These machines produce attractive, crystalline cubes weighing 13g which rapidly chill and enhance the appearance of any beverage.

The Brema IC18A is a bench top ice cube machine that produces 22kg of ice per 24 hours and has storage capacity of 4kg.

The IC range of self-contained ice cube machines is the perfect fit for in cabinet installations as the machine breathes in and out through the front.

STANDARD FEATURES

- 22kg production per 24 hours
- 4kg storage capacity
- Produces crystalline 13g cubes
- Hospital grade stainless steel outer
- Fully insulated internal storage bin
- Disappearing insulated door
- Electromechanical operation
- Stainless steel spray arm

STANDARD ACCESSORIES

- Water inlet hose
- Drainage hose
- External water filter
- Pressure limiting valve
- Plastic ice scoop
- 5mm plastic feet (4)



13g Cubes

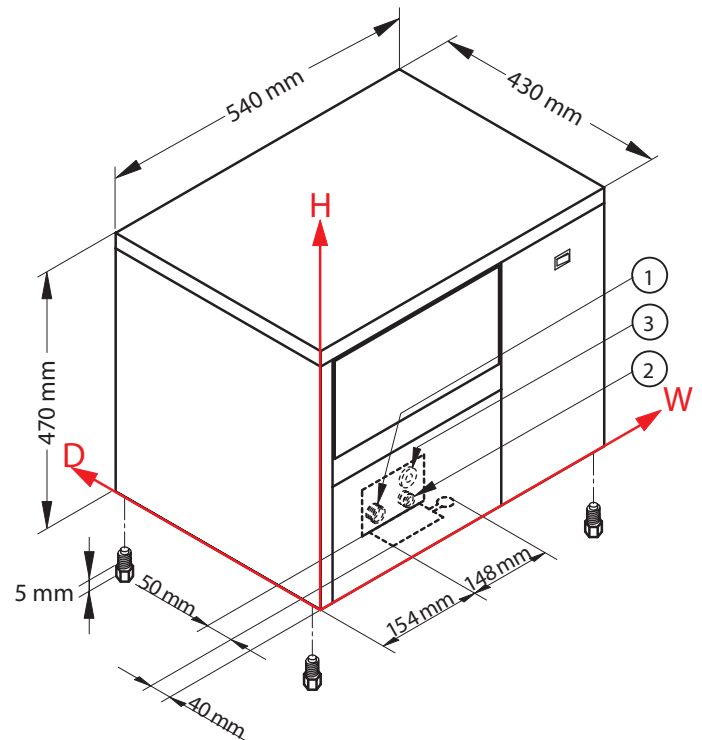
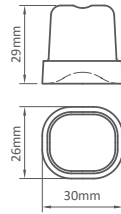

DIMENSIONS

540W x 430D x 470*H mm (*add 5mm for foot)

Clearances: Rear: 100mm Sides: 100mm

POWER SUPPLY

240V 50Hz 10A single phase (plugged)

CONNECTIONS

3/4" Water inlet, 24mm Water outlet & Electrical connection

TECHNICAL DATA

Energy Consumption: 320W

Production 24h: 22kg

Storage Capacity: 4kg

Cooling System: Air

Cube: 13g

Refrigerant: R452A

Weight: 34kg

WaterMark: Yes

SPECIFICATIONS ARE SUBJECT TO CHANGE WITHOUT NOTICE.

