

Gas heated self contained 150L tilting kettle with solid state controls for accurate temperature control ($\pm 1^{\circ}\text{C}$) and low water safety. All exterior surfaces are stainless steel.

STANDARD FEATURES

- Automatic electronic spark ignition system.
- Supplied with gas pressure regulator.
- "Splash-Proof" rear-mounted pressure/vacuum gauge.
- Kettle and all exterior surfaces are a 304 Stainless Steel with a #4 finish.
- Energy efficient (65%), high performance gas-fired heating system for fast heat-up and recovery time:
- Steam jacket permanently filled with treated distilled water; venting and/or refilling is not required.
- 50 psi Steam Jacket Rating. Safety valve mounted toward rear of kettle to avoid tampering.
- Tilt mechanism of roller bearings and case hardened self-locking worm and segment gear.
- 316 Stainless Steel Liner (316)
- Spring Assist Cover (CHS40)
- 51mm Tangent Draw-Off Valve (TD2)
- Support Legs with level adjustable feet, flanged for floor bolting.
- Large pouring lip for easier, faster, pouring. Heavy-duty rolled rim design provides strong reinforcement, prevents damages from abuse.
- Precise, consistent temperature control, less than 1°C temperature variance (ideal for simmering). Operating temperature range from 63°C - 127°C .
- "Splash-Proof" Solid-State control panel for temperature, low water safety, and Power "On/Off" Switch.

ACCESSORIES

- Kettle Markings (KM2L - factory fitted)
- Lift Off Cover (CL40)
- Basket Strainer (TBS40)
- Measuring Strip (MS40)
- Food Strainer (FS40)
- 76mm Butterfly Valve (BV3) AC - factory fitted
- Kettle Accessory Kit (KAK) includes: Clean-up Brush (CB) - 914mm Kettle Paddle (KP), 914mm Kettle Whip (KW) - 914mm Kettle Brush, Draw-Off Brush (DB) - 24 oz. Ladle (KL)
- Hot and cold water faucet (DPK22), or cold water (SPK22).

TECHNICAL DATA

Power Supply: 1NAC 240V, 1 Phase, 50Hz 5amp
(2.5m Cable & Plug included)

Gas Consumption: 144mj
Gas Type: Natural or Propane
Gas Connection: 3/4"

Capacities (per kettle):
(in 230 gram servings, other sizes may be calculated)
40 gallons / 150 litres - 640 servings
AGA Approval no.: AGA 7974G

SHIPPING DATA

Shipping Weight: 250 kg
Shipping Dimensions: 1244W x 1244D x 1372H mm

SPECIFICATIONS ARE SUBJECT TO CHANGE WITHOUT NOTICE.



KGL40T - OPT shown

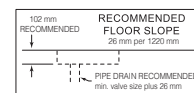
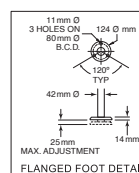
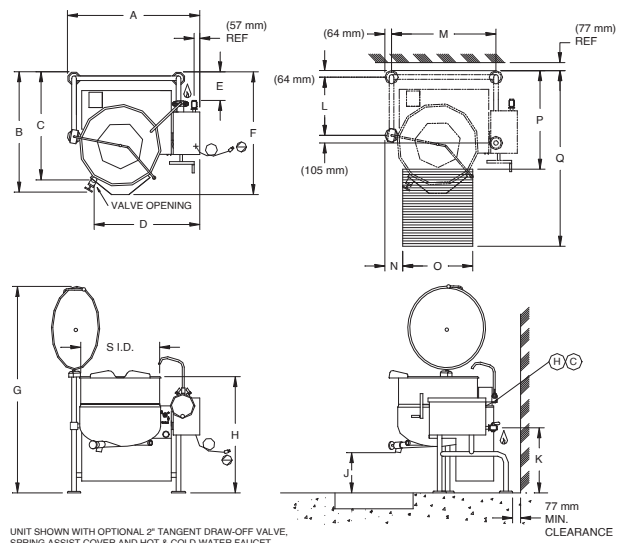

WATER	CLEARANCE
1/2" dia. Soft Copper Tubing (each)	RiGHT = 0" LEFt = 0" REAR = 3"
When ordered with optional faucet.	Allow 6" space minimum from rear and sides when located near combustible walls. 12" recommended on right side for service

DIMENSIONS

LITRES	A	B	C	D	E	F	G	H	J	K	L	M	N	O	P	Q	S.I.D.	
150	mm	1163	108	966	889	229	1074	1804	1029	394	591	483	909	112	610	839	1601	661