



HMB AB-SB 75, 110, 160

CHARCOAL OVEN WITH CUPBOARD BELOW AND WARMING RACK

MIBRASA® is a closed barbeque grill invented in Spain. Made from the best quality steel by expert hands, our grills are designed to satisfy even the most demanding chefs.

The technical specifications allow the user to accurately control the air flow through the grill, changing the intensity of the embers. This is an extremely efficient way of cooking and cuts down the amount of charcoal needed.

MIBRASA® charcoal ovens allow you to cook all types of foods retaining the natural flavours and bringing out a unique taste.

STANDARD FEATURES

- Amazing results for all types of foods: meat, fish, vegetables
- 2 in 1 = Oven and Grill
- Faster and cleaner than an open grill using less consumption of charcoal (approximately 40% less).
- Increased control of heat - for maximum grilling quality.
- Everyone loves the natural flavours that cooking over Coals impart!!



Shown with optional Firebreak

TECHNICAL INFORMATION	HMB 75	HMB 110	HMB 160
Diners*	75	110	160
Fire up time* (min)	25	30	35
Cooking temperature (°C)	250-350	250-350	250-350
Charcoal consumption* (kg/day)	13	18	20
Production* (kg/h)	70	100	120
Performance* (h)	9	10	10
Useful dimensions of grill (mm)	500 x 600	720 x 600	720 x 800
Equivalent power* (kW)	3,5	5	6
Exhaust rate (m³/h)	2000	2400	2600

* Approximate data

INCLUDED ACCESSORIES

- Grill
- Oven tongs
- Charcoal ember poker
- Ash shovel
- Grill brush

OPTIONAL ACCESSORIES

- Extra grill
- Firebreak
- Dissipating filter
- Cookware
- Steel wheels with brakes

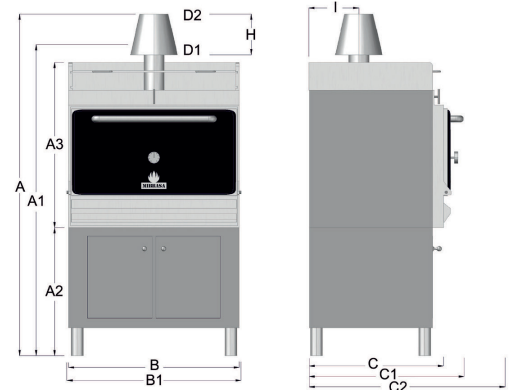

Model	A	A1	A2	A3	B	B1	C	C1	C2	H	I	D1	D2
HMB AB SB 75	1810	1630	740	800	700	730	640	820	1080	230	300	115	150
HMB AB SB 110	1860	1680	690	890	920	950	640	820	1170	230	300	115	15
HMB AB SB 160	1860	1680	690	890	920	950	840	1020	1360	230	350	115	150

