

The Premier series of benchtop vacuum packaging machines offers the ultimate in vacuum sealing technology all incorporated as standard into one unit.

STANDARD FEATURES

- Stainless steel housing and deep-drawn vacuum chamber for optimal hygiene
- Removable wireless sealing bar
- Insert plates for adjusting vacuum chamber height
- Vacuum - Optimal final vacuum 99.80% (2 mbar)
- Soft-air - Controlled ventilation for protection of product and packaging
- 2 x 3.5mm seal wires for an extra-strong double seal
- Sensor Control - Set percentage pressure for vacuum and gas functions for accurate and constant packaging results / Automatic programming / 10 default programs / Vacuum plus time
- Stop button for partial/full cycle interruption
- Digital maintenance program for pump / Operating hours counter / Service indicator programs / Sleeper function etc
- Service kit for user maintenance

OPTIONAL FEATURES

- Inclined insert plate for packing liquid products
- Trolleys with 3 shelves and lockable castors
- Gas-flush - Injecting food-gas for product protection and longer shelf life



DIMENSIONS

External dimensions: 493W x 616D x 440H mm

Chamber: 420W x 460D x 180H mm

Sealing Bar: 420mm

TECHNICAL DATA

Power supply: 240V, 50Hz, Single Phase

Power output: 1.0kW

Capacity pump: 21 m³/h

Machine cycle: 20-40 seconds

Weight: 67kg

SPECIFICATIONS ARE SUBJECT TO CHANGE WITHOUT NOTICE.

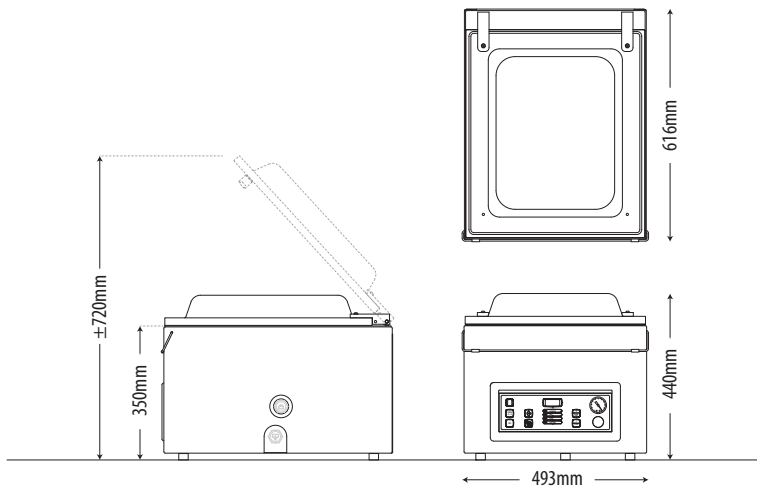

Busch vacuum pumps, world leaders in vacuum pump technology.



Two years parts and labour warranty



National Head Office
156 Swann Drive
Derrimut VIC 3026
Tel: +61 3 8369 4600
Fax: +61 3 8369 4699
www.comcater.com.au

Melbourne
96-100 Tope Street
South Melbourne VIC 3205
Tel: +61 3 8699 1200
Fax: +61 3 8699 1299

Sydney
20/4 Avenue of the Americas
Newington, NSW 2127
Tel: +61 2 8775 9500
Fax: +61 2 9648 4762

Brisbane
1/62 Borthwick Avenue
Murarrie QLD 4172
Tel: +61 7 3900 2700
Fax: +61 7 3399 5311

Perth
Unit 16, 7 Abrams Street
Balcatta, WA 6021
Tel: +61 8 6217 0700
Fax: +61 8 6217 0799