

The ULTRA63522ACS floor model vacuum packaging machine delivers extreme power and the ultimate in technology all incorporated as standard into one unit.

STANDARD FEATURES

- Stainless steel housing & deep-drawn vacuum chamber for optimal hygiene
- Removable wireless sealing bar
- Insert plates for adjusting vacuum chamber height
- Gas-flush - Injecting food-gas for product protection and longer shelf life
- Soft-air - Controlled ventilation for protection of product & packaging
- Sensor Control - Set percentage pressure for vacuum & gas functions for accurate & constant packaging results
- Stop button for partial / full cycle interruption
- Digital maintenance program for pump / Operating hours counter / Service indicator programs / Sleeper function etc
- Service kit for user maintenance

ADVANCED CONTROL SYSTEM (ACS) FEATURES

- Easy to use - 4.7 inch full colour LCD screen
- Intuitive programming based on icons + animated process steps
- 20 personalised programs - settings can be made on PC
- Settings can be saved ensuring consistent results every time
- Secured access. 3 different access levels with authorisation codes - User / Owner / Dealer
- Customised screen saver / logo
- Real time / date displayed
- Special programs - red meat, marinating, tenderising, sequential and external vacuum
- Liquid control - sensor to detect the boiling point of liquid products. Developed to pack meat products and liquids such as soups, sauce and marinades. Conserves the quality and weight of product.

SERVICE FEATURES

- Store: Operation hours / process cycles / pump cleaning cycles
- Optional - forced service reminder and pump cleaning program
- Service data exportable by USB
- Complete testing mode for all functions
- Software update by USB

OPTIONAL ACS FEATURES

- Zebra Label printer
- Inclined insert plate for packing liquid products
- CUT-OFF Seal Bar

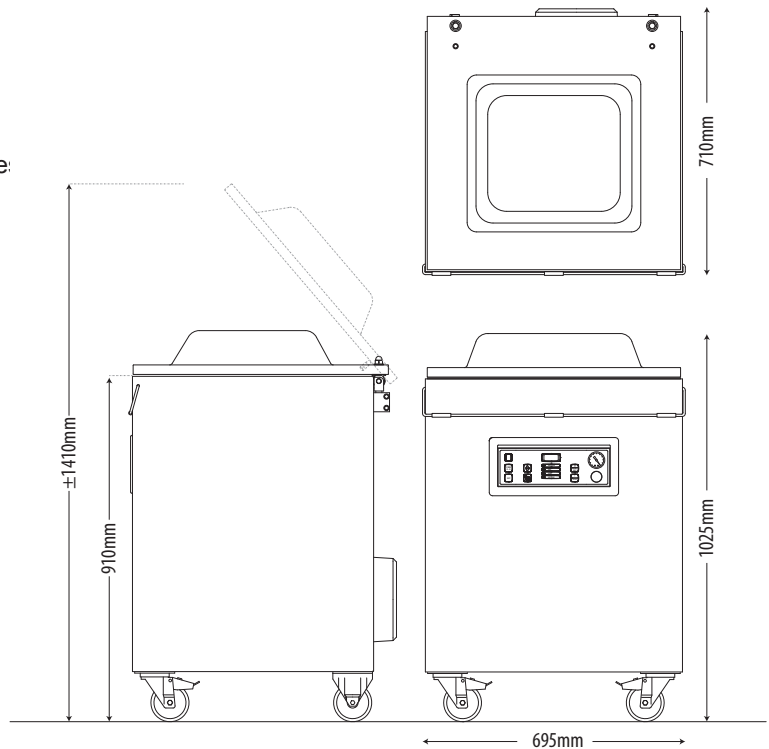

DIMENSIONS

External dimensions: 695W x 710D x 1025H mm

Chamber: 500W x 520D x 200H mm

Sealing Bar: 2 x 520mm

TECHNICAL DATA

Power supply: 415V 3AC 50Hz (Includes Lead but not Plug)

Power output: 3.5kW

Capacity pump: 63 m³/h

Machine cycle: 15-40 seconds

Weight: 143kg

SPECIFICATIONS ARE SUBJECT TO CHANGE WITHOUT NOTICE.



Busch vacuum pumps, world leaders in vacuum pump technology.



Two years parts and labour warranty



National Head Office
156 Swann Drive
Derrimut VIC 3026
Tel: +61 3 8369 4600
Fax: +61 3 8369 4699
www.comcater.com.au

Melbourne
96-100 Tope Street
South Melbourne VIC 3205
Tel: +61 3 8699 1200
Fax: +61 3 8699 1299

Sydney
20/4 Avenue of the Americas
Newington, NSW 2127
Tel: +61 2 8775 9500
Fax: +61 2 9648 4762

Brisbane
1/62 Borthwick Avenue
Murarrie QLD 4172
Tel: +61 7 3900 2700
Fax: +61 7 3399 5311

Perth
Unit 16, 7 Abrams Street
Balcatta, WA 6021
Tel: +61 8 6217 0700
Fax: +61 8 6217 0799