



Blast chiller



Icecream



Conservation cycle



Thawing



Chilling programs



Ozone

Features

- Thickness insulation walls 70 mm
- AISI 304 stainless steel construction
- Hot gas defrosting and Forced ventilation
- 7" Touch control
- Functions available: Blast chilling, blast freezing, Blast freezing continuous, automatic blast chilling - thawing - ice cream- conservation- user set programs - HACCP report alarms
- Upload and Download data with USB
- Condensing unit with box



Optional

- Ozone Sanitation
- Water cooled condenser
- 60Hz versions
- Special floor H22 mm
- Without condensing unit
- Soundproof condensing unit
- Additional door (pass through)

Capacity

CT40-150



150 kg

+90°C → +3°C



135 kg

+90°C → -18°C



1 600 x 1000 mm

Combi steamer trolley

GN 2/1

Predisposed **WI-FI** connection



CT40-200



200 kg

+90°C → +3°C



175 kg

+90°C → -18°C



2 600 x 400 mm

Features

	CT40-150	CT40-200	CT40 CT-C
Code number			
Power supply	400V/3N/50HZ	400V/3N/50HZ	230V/1N/50HZ
Outside length	1550 mm	1550 mm	1550 mm
Depth	1370 mm	1370 mm	1370 mm
Height	2470 mm	2470 mm	2470 mm
Absorbed power / Max Current	7400 W / 22A	9600 W / 27A	1400 W / 6A
Cable size	5 x 4,0 mm ²	5 x 4,0 mm ²	3 x 2,5 mm ²
Output chilling (+90°C/+3°C)	150 kg	200 kg	---
Output freezing (+90°C/-18°C)	135 kg	175 kg	---
Cabinet Shipment data	cm / kg 250 x 165 x 144 mm / 580 kg	250 x 165 x 144 mm / 580 kg	250 x 165 x 144 mm / 580 kg

REMOTE UNIT FEATURES (max distance 10 m)

Refrigeration Power (-20°C/+40°C)	10970 W - 5,5 HP	14270 W - 7,5 HP	
Defrost	Hot Gas	Hot Gas	
Diameter Discharge Pipe mm	12	12	
Diameter Suction Pipe mm	28	28	(without C.U.)
Diameter Hot Gas Pipe mm	10	10	
Refrigeration Fluid	R452a / R404A	R452a / R404A	
C.U. Shipment data	cm / kg 95 x 160 x 85 (310 Kg)	96 x 158 x 85 (320 Kg)	

Dimensions

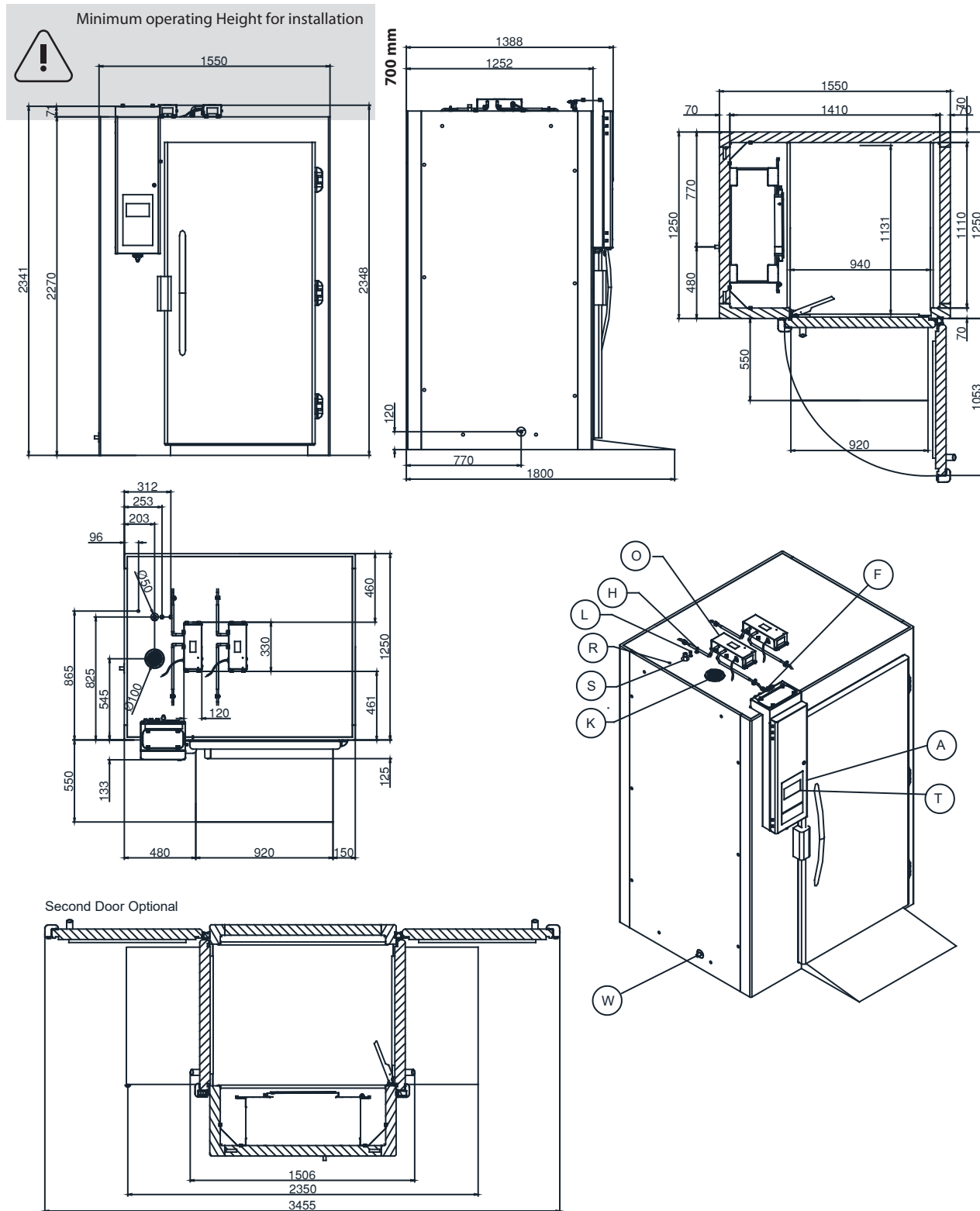

- Ozone Box
- H Hot gas line
- W Water discharge Ø 20 mm
- K Compensazione valve
- S Suction gas line
- A Electric Box
- R Cables outlet
- L Liquid line
- T Touch Panel 7"

○ F Wi-Fi Connection

⚠ Cable RJ45 CAT. 5 STP max 100 m

Chill TOUCH
WI-FI



National Head Office
156 Swann Drive
Derrimut VIC 3026
Tel: +61 3 8369 4600
Fax: +61 3 8369 4699

Melbourne
96-100 Tope Street
South Melbourne VIC 3205
Tel: +61 3 8699 1200
Fax: +61 3 8699 1299

Sydney
20/4 Avenue of the Americas
Newington, NSW 2127
Tel: +61 2 8775 9500
Fax: +61 2 9648 4762

Brisbane
46-60 Dunhill Crescent,
Morningside, QLD 4170
Tel: +61 7 3900 2700

Perth
Unit 16, 7 Abrams Street
Balcatta, WA 6021
Tel: +61 8 6217 0700
Fax: +61 8 6217 0799

Condensing Unit

5,5 HP

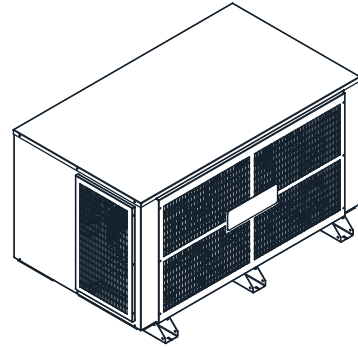
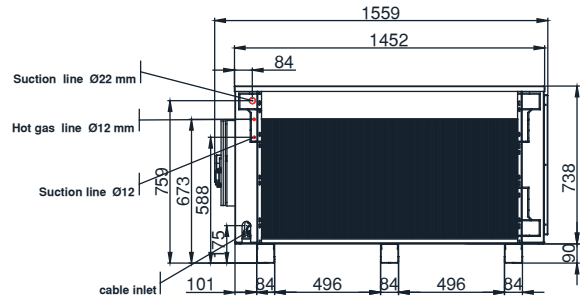
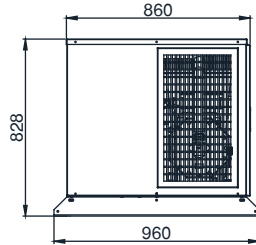
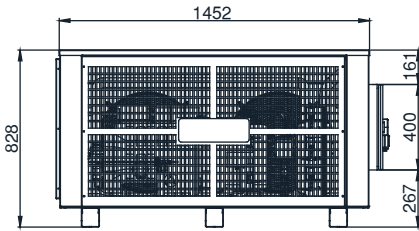

7,5 HP

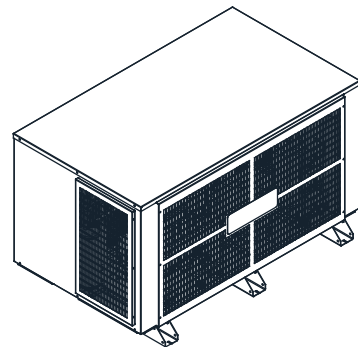
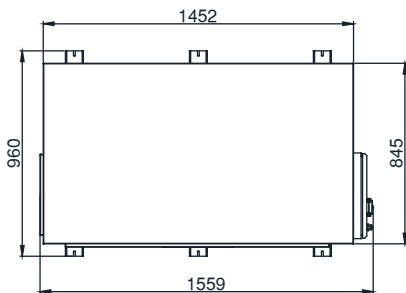
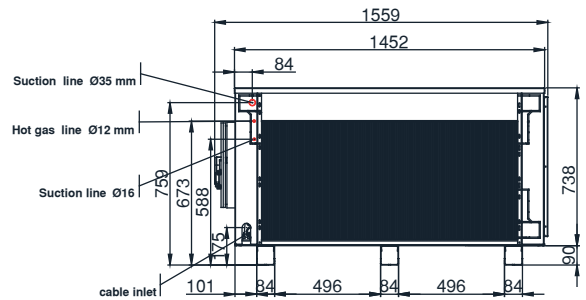
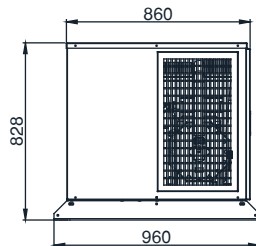
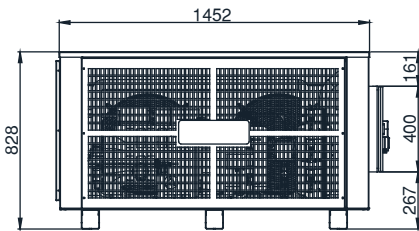

Functions

Version	Blast chiller cycles	Ice cream cycle	Conservation cycle	Thawing cycles	Ozone cycle	Hot gas defrosting	Stored Programs	Variable speed fans evaporator	Variable power resistance	Dynamic Frost Control	Load/Download data-USB
START	●	●	●	●		●	●			●	●
FULL	●	●	●	●	●	●	●			●	●

7" TOUCH INTERFACE



Predisposed **WI-FI** connection

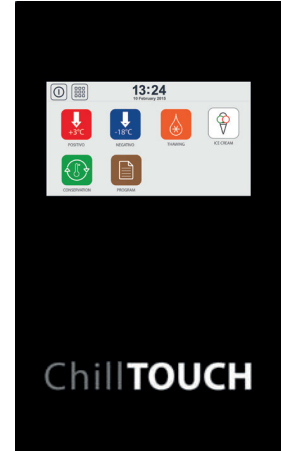

Electrical connections

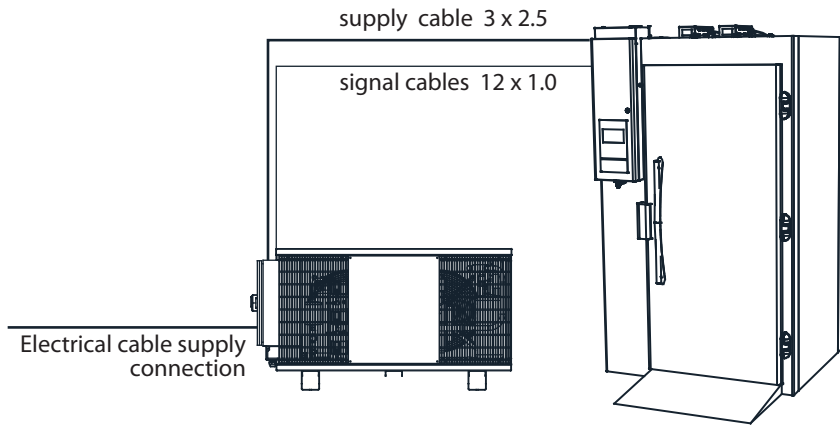

Machine delivered without condensing unit

Disclaimer Clause

Castelmac guarantees only the good functioning of the components of the machine. It's excluded from the warranty:- the cooling performance of the machine malfunctioning or damages due to the partial or not complete connection of the machine with the central cooling unit or the non-original condensing unit. In particular there is no warranty on damages on the machine due to the missed connection of the alarm input which stops the machine in case of alarm coming from the central cooling unit or the non-original condensing unit. Hot gas defrosting available only if hot gas supplied (distance < 25 m). Alternative air defrosting available from control panel.

Connection to condensing unit NOT supply by Tecnomac

- Output signal supplied for switch on compressor
- Output signal supplied for switch on hot gas valve (if present)
- Input signal available for alarm coming from the condensing unit, which stops the machine

Connection to central cooling unit

- Blast Freezing function must be disabled (do not work)
- Use the freezing line (-28°C / - 30°C Evaporation)
- Output signal supplied for liquid line valve control (valve not supplied)
- Input signal available for general alarm from the central cooling unit, which stops the machine

Aerated Excavation

For running , less than 16 hours a day

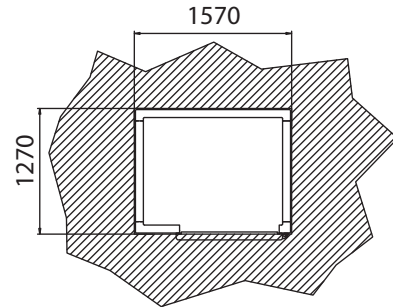
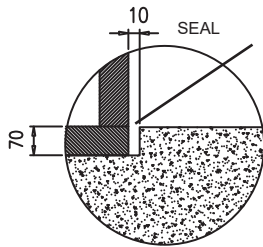

For running 24 hours a day with removable gate

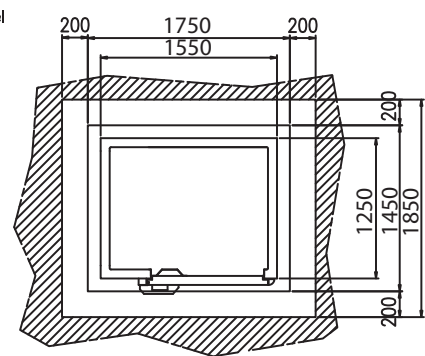
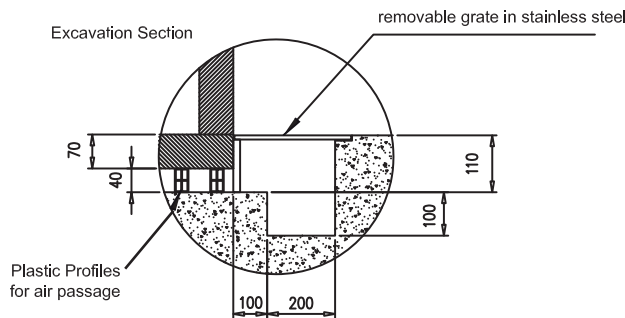
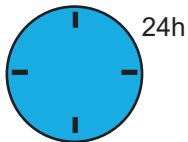

Excavation example

For running 24 hours a day with ventilation chimneys

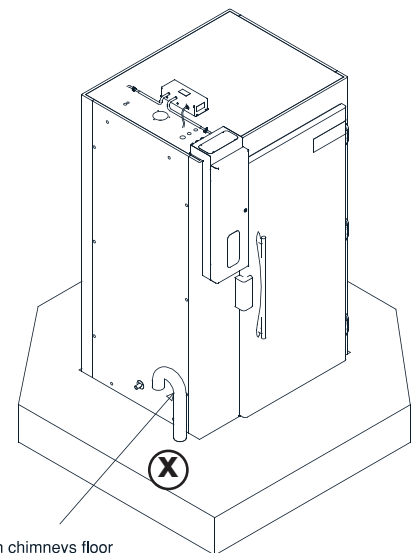
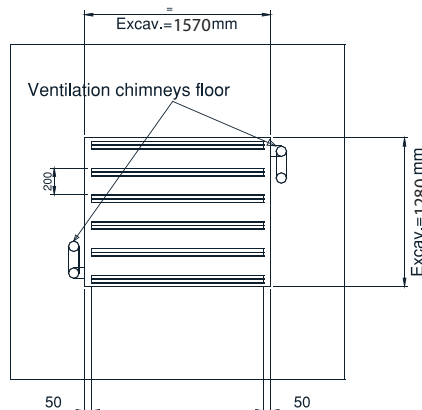
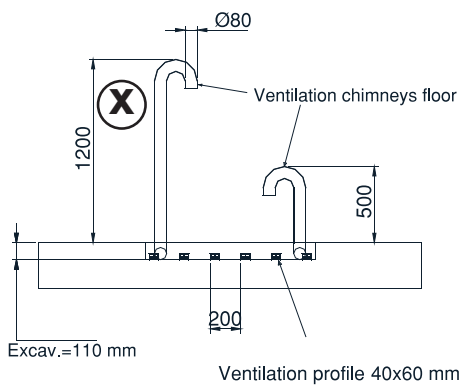

! Masonry work and chimneys, charged to the customer.