

HIGH PRODUCTION FOOD BLENDER

Maximize your kitchen’s possibilities with the largest capacity, countertop blender. Blend up to 24 (200ml) servings at once! The XL is engineered to reduce prep-time, improve staff efficiency, and expand your menu capabilities

SMART PRODUCT DESIGN

- Powerful 4.2 peak output HP motor allows heavy blending from delicate tomatoes to dense meat
- Large 5.6 litre container provides extra blending capacity for both hot and cold ingredients
- Pulse function and variable speed control allow for flexibility and

STANDARD FEATURES:

- XL Blade
- 5.6 litre and 2.0 litre high impact clear container
- Basic Start/stop function
- 1-10 speed settings
- Pulse switch
- Tamper stick

PACK INCLUDES:

Vitamix XL® Variable Speed with accelerator tool and 2 containers (5.6 litre and 2.0 litre) complete with blade assembly and lid



Three year parts and one year labour warranty on motor and base. One year warranty on the container, lid, blade assembly, drive socket and sound enclosure against defects in material and workmanship.

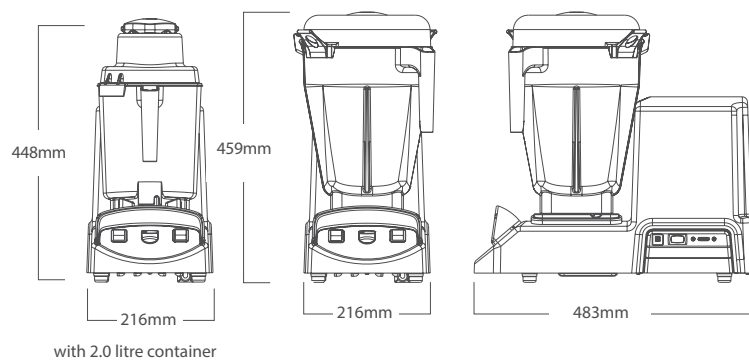

DIMENSIONS

216W x 483D x 459H mm

TECHNICAL DATA

Power Supply: 240V, 50Hz, 10A
 Power Output: 1700W-1900W
 Motor: ≈ 4.2HP
 Weight: 22.7kg

SPECIFICATIONS ARE SUBJECT TO CHANGE WITHOUT NOTICE.